

PRESSURE REDUCING VALVE FOR STEAM RP 45

DESCRIPTION

The ADCA RP45 series pressure reducing valves are single seat bellows sealed controllers, operating without auxiliary energy, designed for use on steam, compressed air and other gases. They are suitable for reducing steam pressure in all energy and process systems where pressures should be kept constant. Connections are flanged.

MAIN FEATURES

Bellows specially designed for high durability.

USE: Saturated steam, compressed air and other gases compatible with the construction.

AVAILABLE MODELS: RP45
SIZES: DN 15 to DN 100
CONNECTIONS: Flanged DIN
INSTALLATION: Horizontal installation.
 An "Y" strainer, steam separator and steam trap should be provided upstream the valve.
 See IMI, installation and maintenance instructions.

LIMITING CONDITIONS

Body design conditions :	PN 16	PN 40
Maximum upstream pressure (steam) :	13 bar	25 bar
Maximum downstream pressure :	13 bar	13 bar
Minimum downstream pressure :	0,15 bar	0,15 bar
Maximum operating temperature :	250 °C	250 °C
Maximum reducing ratio :	25 : 1	25 : 1
Maximum cold hydraulic test :	24 bar	25 bar
Max.hydraulic factory valve body test:	24 bar	60 bar

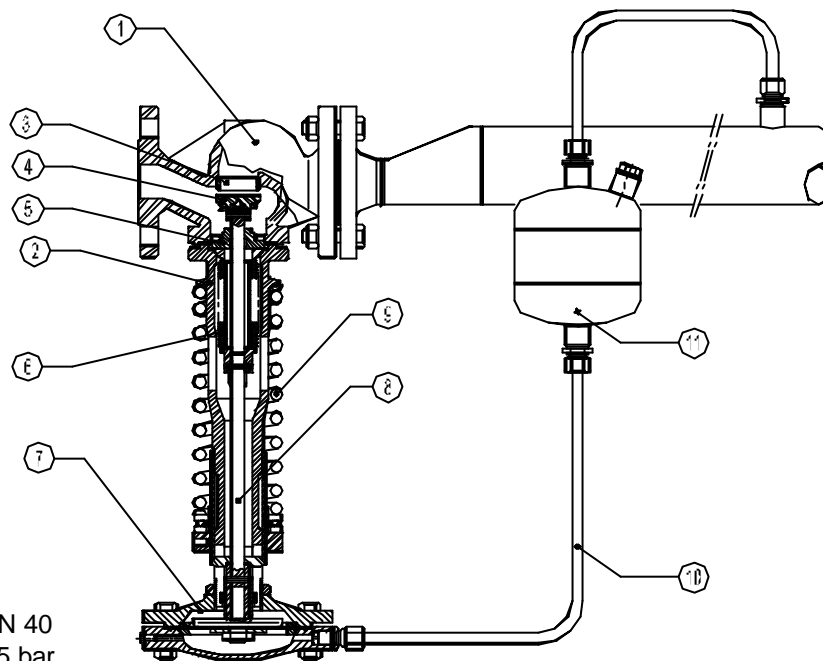

MATERIALS

POS.	DESIGNATION	MATERIAL
1	BODY (PN16)	GG-25
1	BODY (PN40)	GS-C 25
2	PISTON BODY	GGG40
3	VALVE SEAT	ST.STEEL
4	VALVE DISC	ST.STEEL
5	GUIDE	ST.STEEL
6 *	BELLOWS	ST.STEEL
7 *	DIAPHRAGM CHAMBER	GG25
8	SPINDLE	ST.STEEL
9	SPRING	SPRING STEEL
10 *	IMPULSE LINE	COPPER
11 *	CONDENSATE VESSEL	STEEL

* Available spare parts.

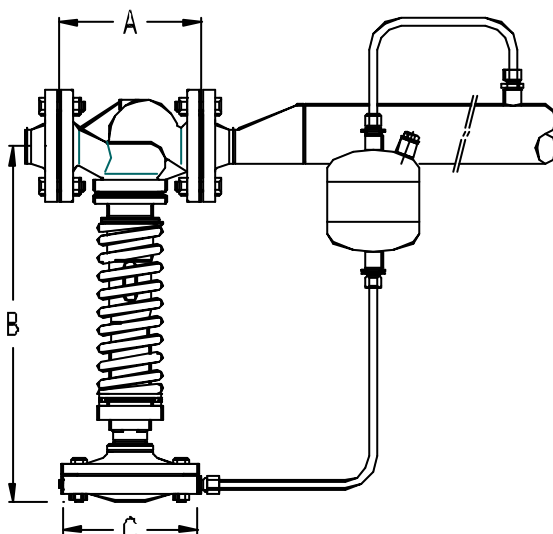

DIMENSIONS (mm)

DN	VALVE			ACTUATOR		
	A	B	Kg	TYPE	C	Kg
15	130	440	12,7	A1	172	4,3
20	150	440	12,7	A11	172	4,3
25	160	440	13,7	A2	220	7,3
32	180	445	15,7	A21	220	7,3
40	200	445	17,7	A3	282	11,3
50	230	540	25,7	A4	340	16,3
65	290	540	29,7			
80	310	610	36,7			
100	350	650	53,7			

CAPACITY TABLE FOR SATURATED STEAM Kg/h

INLET PRESSURE bar	VALVE SIZE								
	DN15	DN20	DN25	DN32	DN40	DN50	DN65	DN80	DN100
0,5	51	68	90	118	186	300	460	800	1250
0,75	63	84	112	146	230	360	580	1000	1550
1	75	100	133	175	280	430	700	1200	1850
1,5	100	133	175	240	360	590	910	1600	2500
2	126	170	230	290	450	730	1160	2000	3050
2,5	150	200	260	350	550	880	1390	2400	3600
3	175	240	310	400	640	1010	1600	2700	4300
4	220	290	390	510	800	1300	2000	3400	5400
5	260	350	480	620	1000	1600	2500	4200	6500
6	330	440	580	760	1220	1930	3000	5100	8000
7	400	520	700	910	1430	2300	3600	6100	9500
8	450	600	800	1040	1670	2700	4100	7100	11000
9	500	670	880	1180	1800	2900	4600	7800	12000
10	560	750	980	1300	2000	3200	5100	8500	13500
12	680	900	1180	1540	2500	4000	6100	10500	16300
14	800	1050	1400	1850	2900	4700	7200	12600	19000
16	920	1230	1630	2150	3400	5500	8300	14600	22000
18	1040	1400	1860	2450	3800	6200	9500	16600	25000
20	1170	1540	2100	2700	4200	7000	10800	18600	28000
22	1330	1780	2350	3050	4900	7800	12200	21000	32000
24	1500	2000	2600	3400	5400	8700	13700	23500	36000
25	1600	2150	2800	3600	5700	9200	14500	25500	38000

ACTUATOR AND SPRING SELECTION TABLE

VALVE DN	Kvs m3/h	ACTUATOR						
		Outlet (bar)	A -4	A -3	A -2	A -21	A -1	A -11
15	4,8	Outlet (bar)	0,5 -0,99	1,0-1,6	1,7-3,8	3,9-5,5	5,6-8,2	8,3-13
		Spring Nr.	60	60	60	60	60	60
20	6,9	Outlet (bar)	0,5 -0,99	1,0-1,6	1,7-3,8	3,9-5,5	5,6-8,2	8,3-13
		Spring Nr.	60	60	60	60	60	60
25	9,1	Outlet (bar)	0,5 -0,99	1,0-1,6	1,7-3,8	3,9-5,5	5,6-8,2	8,3-13
		Spring Nr.	60	60	60	60	60	60
32	11,8	Outlet (bar)	0,5 -0,99	1,0-1,6	1,7-3,8	3,9-5,5	5,6-8,2	8,3-13
		Spring Nr.	60	60	60	60	60	60
40	14,4	Outlet (bar)	0,5 -0,99	1,0-1,6	1,7-3,8	3,9-5,5	5,6-8,2	8,3-13
		Spring Nr.	60	60	60	60	60	60
50	26,5	Outlet (bar)	0,5 -0,99	1,0-1,9	2,0-4,2	4,3-6,9	7,0-8,5	8,6-13
		Spring Nr.	61	61	61	61	64	64
65	51,5	Outlet (bar)	0,5 -0,99	1,0-1,9	2,0-4,2	4,3-6,9	7,0-8,5	8,6-13
		Spring Nr.	61	61	61	61	64	64
80	79,5	Outlet (bar)	0,46-0,99	1,0-1,9	2,0-5,0	5,1-8,9	9,0-13	-----
		Spring Nr.	62	62	62	62	65	-----
100	129,5	Outlet (bar)	0,46-0,99	1,0-1,9	2,0-6,0	6,1-13	-----	-----
		Spring Nr.	63	63	63	63	-----	-----

Correction factors: Correction factors must also be used for certain pressure ratios as follows:

$$\frac{\text{Downstream pressure} + 1}{\text{Upstream pressure} + 1} \geq 0.7 \rightarrow \text{correction factor } f = 1.25; \geq 0.8 \rightarrow \text{correction factor } f = 1.6; = 0.9 \rightarrow \text{correction factor } f = 2.25$$

Remarks: The pressures have to be inserted in barg. No correction factor should be used for smaller pressure ratios than 0,7

Example (valve selection): Saturated steam capacity 300 Kg/h ; Upstream pressure:3 bar ; Downstream pressure required : 2 bar

Solution :First determine correction factor for pressure ratio $\frac{2+1}{3+1} = 0,75 \rightarrow f = 1,25$, multiply the given capacity 300 x 1,25 = 375 kgs/h

Go to 3 bar in the column "bar" of the capacity table. By following the horizontal line you can find out the values for selection of pressure reducing valve. Looking for an equal or higher value than 300 Kg/h. In this case it will be 400Kg/h.

Now, go to the top of the table and read off the nominal size : DN 32.

On the actuator and spring selection table, for downstream pressure of 2 bar we may see that the recommended actuator is type A-2, considering the valve supplied with spring Nr.60.

How to order : RP45 DN 32 PN 16 valve complete with spring Nr.60 ,type A-2 actuator,condensate vessel and copper tube impulse line.

Remarks: For superheated steam please consult. For determination of upstream and downstream pipe sizes please consult.